



Category: Soft Drinks

Spring Water

#4009

Specification

Fill-Point Capacity	30cl
Weight	210g
Bottles per Pallet	3690

Bottle Dimensions

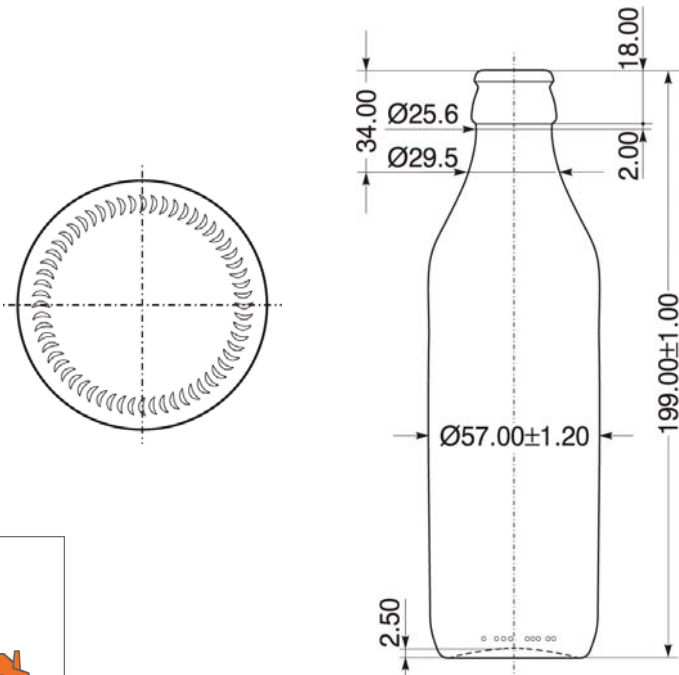

FOR FURTHER INFORMATION

Call 0845 200 2835
glassworksinternational.com